



emPower R3

emWall - emActuator

READ AND SAVE THESE INSTRUCTIONS

Thank you for purchasing this AgriMesh product. Please read these instructions carefully before attempting to install, use or repair the AgriMesh product. Failure to follow these instructions can result in personal injury or property damage. Please explain to the user how to use and maintain the product once installed and this manual should be given to the user. Keep this manual for future reference.

SAFETY INSTRUCTIONS

For your safety in order to reduce the risk of injury, death, electric shock, fire, malfunction and damage to equipment or professionals, always observe the safety instructions below.

Explanation of Warning Signs The following warning signs are used to classify and indicate the levels of risk, injury and property damage resulting from failure to follow the warning and improper use.



Indicates a potential hazard that could result in death or serious injury.

	The symbols below are used to classify and indicate the types of instructions to be observed.
	This symbol is used to alert users to the presence of a specific procedure to follow in order to use the device safely.
	This symbol is used to alert users to the presence of a specific procedure to follow in order to use the device safely.
	This symbol is used to alert users not to dismantle equipment for reconstruction to reduce the risk of fire and electric shock.
	This symbol is used to alert users to ensure proper earthing when using the equipment with the earthing terminal.

**CAUTION**

	Use this device under the conditions specified by the manufacturer. For further information, contact the manufacturer.
	Installation and electrical wiring must be done by qualified personnel and in accordance with all applicable regulations and standards, including those relating to fire protection.
	When drilling a hole in a wall or ceiling, take care not to damage the electrical system wires or other installations.
	Before repairing or cleaning the unit, turn off the power supply on the control panel and lock it to prevent accidental ignition. When locking is not possible, put a very visible notice on the control board.
	Never mount an AgriMesh product in a position accessible from a bath, shower or drinking trough.
	Do not disassemble the unit to rebuild it. This may cause a fire or electric shock.
	The mounting location of the product must be able to withstand a static load more than five times the weight of the product.
	This appliance must be connected to the ground.

**CAUTION**

	Do not install the AgriMesh in a location where the temperature may exceed 60 ° C (140 ° F).
	Make sure that the voltage delivered by the mains is 120V or 240V, 60Hz.
	Observe the regulations and standards for safety and installation of electrical equipment in force as well as the National Electrical Code (NEC) and the Ordinance on the Protection of Workers (OSHA).
	Always unplug the unit before opening the protective cover or repairing the devices connected to it.
	Make sure that the device (s) connected to the AgriMesh device comply with the product limitations described in this manual.
	Make sure that the device (s) connected to the AgriMesh appliance comply with the electrical standards and electrical equipment regulations in force.
	Make sure that the device (s) connected to the AgriMesh device include their own protection for overvoltage or overheating due to malfunction.
	This device should not be used to control a device that requires urgent and instantaneous response.

Contents

SAFETY INSTRUCTIONS	2
Contents	5
Description	6
Unpacking	6
Supplied Accessories	6
Dimensions	7
Installation	8
Wiring plan	11
Special Wiring	13
emActuator	13
emWall	13
Specifications	14
Operation	15
Maintenance	16
Fuse change	16
Warranty	17
Certifications	18

Description

The AgriMesh emPower R3 is a wireless control device controlling 3 relay outputs. It must be used in communion with an AgriMesh emHub system so that it can be used.

Each of the relay outputs can be used at a maximum voltage of 240 volts and a maximum current of 15 amperes. If used for motors the maximum load per relay and from 0.5HP to 120V and 1HP to 240V.

The device is protected against over-voltage and over-consumption.

Unpacking

Unpack and remove the unit from the carton with care. Refer to the list of supplied accessories to verify that no parts are missing.

Supplied Accessories

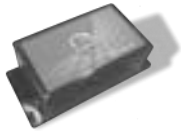
	EmPower R3 housing	1
	Door contactor (emDoor option only)	1*

Dimensions

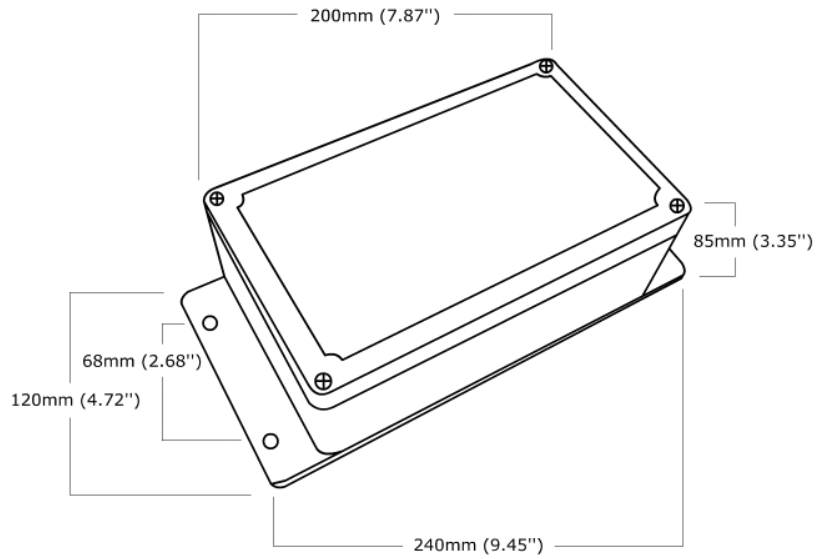



Installation

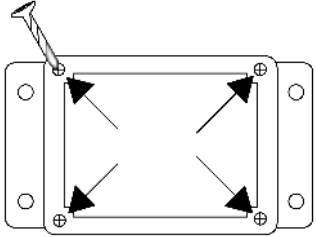

Step #1

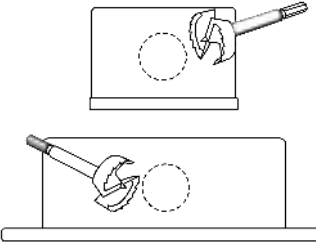
	<p>Carefully remove the four (4) screws from the emPower enclosure cover.</p> <p>Special care must be taken not to lose the seal between the cover and the main housing.</p> <p>Remove and preserve the four (4) screws and cover for later.</p>	
---	--	--

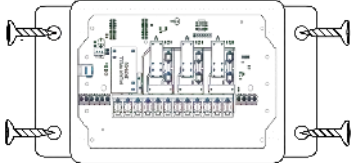

Step #2

	<p>Drill one or more grommet holes according to your needs and with a suitable wick.</p> <p>In order to maintain the waterproof nature of the box, it is strongly suggested not to drill a hole on the side that will be placed upward.</p>	
---	---	---

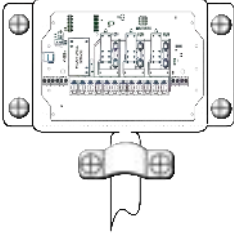

Step #3

	<p>Place and secure the emPower R3 housing to the wall with appropriate screws.</p> <p>Make sure that the screws do not pierce a wire passing behind the wall. Ask for the expertise of an electrician if in doubt.</p>	
---	---	---

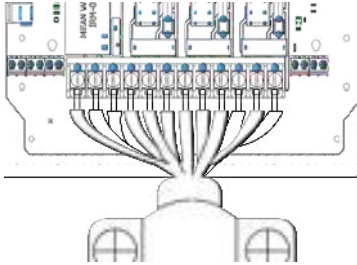

Step #4

	<p>Install your protective piping.</p> <p>Make sure that the waterproofing of the joint is done properly so that water does not enter the housing.</p>	
---	--	---

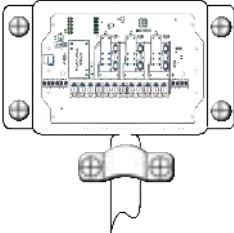

Step #5

	<p>Before plugging in, make sure the circuit breakers are closed and there is no current on your wires.</p> <p>Connect the wires to the terminal blocks provided for this purpose.</p> <p>Refer to the connection plan to ensure that the connections are adequate. It is important to have this task inspected by a certified electrician before power is restored.</p>	 
---	--	--

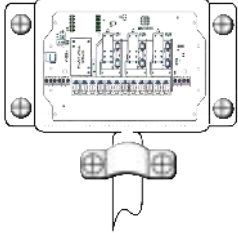

Step #6

	<p>Turn on the breaker. An orange light (LED) should light on the device.</p> <p>At this stage the unit is under voltage. Contact with the wires or the circuit board could result in injury or death. This step should be done by a certified electrician.</p>	
---	---	---

Step #7

	<p>For this step, make sure the emHub of your system is functional. Refer to the emHub manual.</p> <p>After a delay of at least 2 minutes, a green LED should light up.</p> <p>At this stage the unit is under voltage. Contact with the wires or the circuit board could result in injury or death. This step should be done by a certified electrician.</p>	
---	---	---

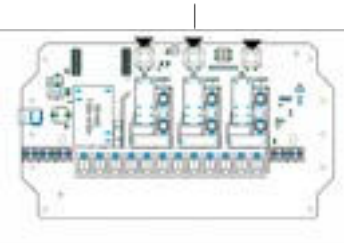
Step #8

	<p>To validate your connections, gently press the test buttons on the device. The relays should trigger and activate the device connected to it according to the specificities chosen.</p> <p>At this stage the unit is under voltage. Contact with the wires or the circuit board could result in injury or death. This step should be done by a certified electrician.</p>	
--	--	---

Step #9

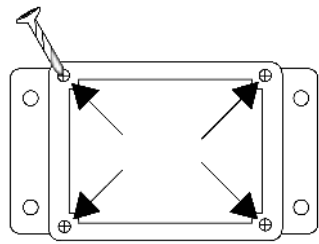
	<p>Trigger the circuit breaker</p> <p>Replace the sealing cord and cover. Replace the screws and tighten them slightly to ensure pressure between the lid and the box.</p> <p>Reset the circuit breaker.</p>	
---	--	--

Wiring plan

240v AC 60Hz

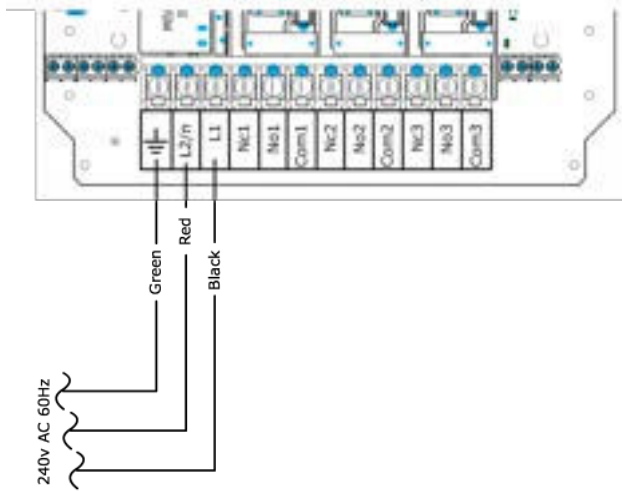

120v AC 60Hz

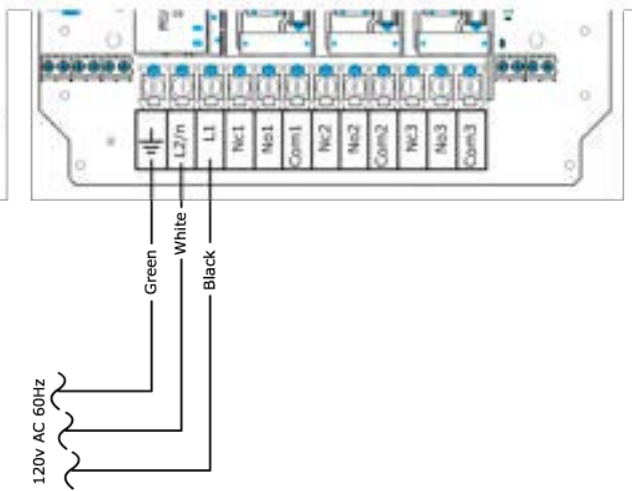

Exemples

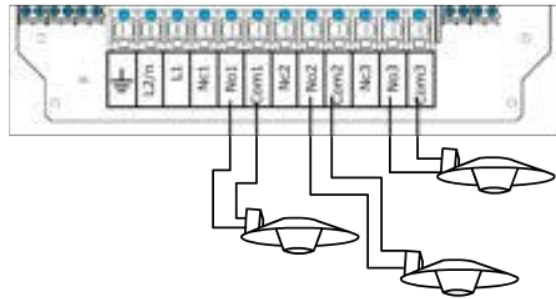
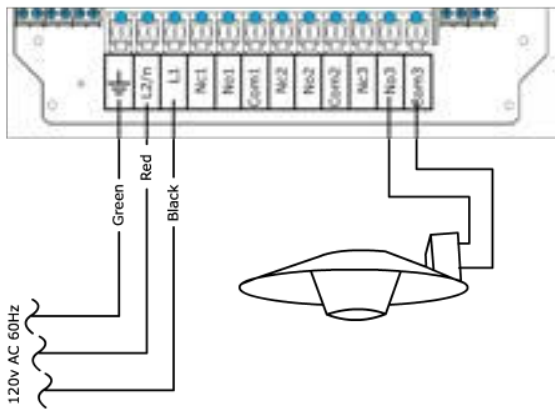
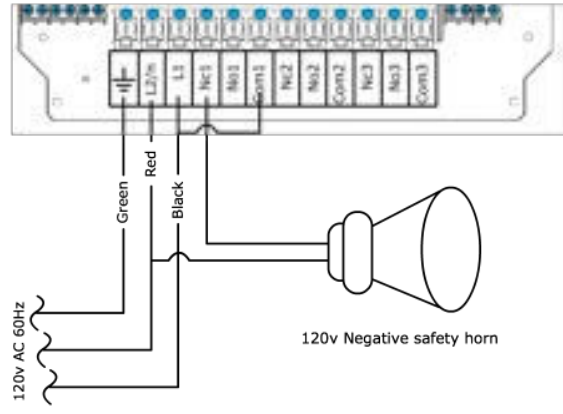
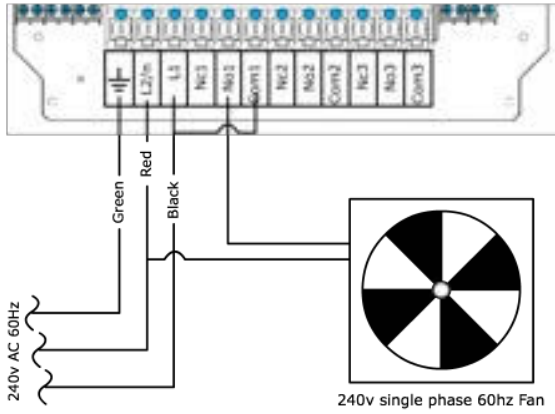

ATTENTION :



Each entry of the emPower R3 can support the following specificities. Do not exceed the maximum allowed.

Type	120v	240v
Current (Max)	15 amperes (Resistive)	15 amperes (Resistive)
If used with a motor	0.5 Hp (Max)	1 Hp (Max)

Special Wiring

emActuator

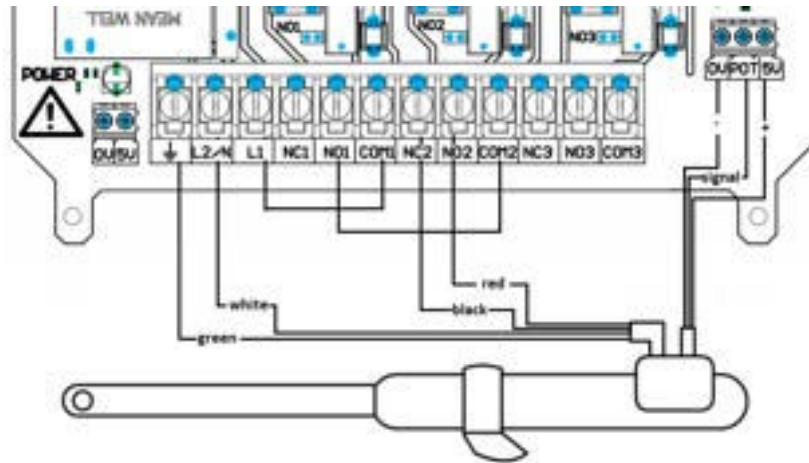

CAUTION :

The installation of an emActuator requires an actuator equipped with limit switches. It is important that the switches are properly adjusted to limit the stroke of the actuator and prevent mechanical breakage.

emWall

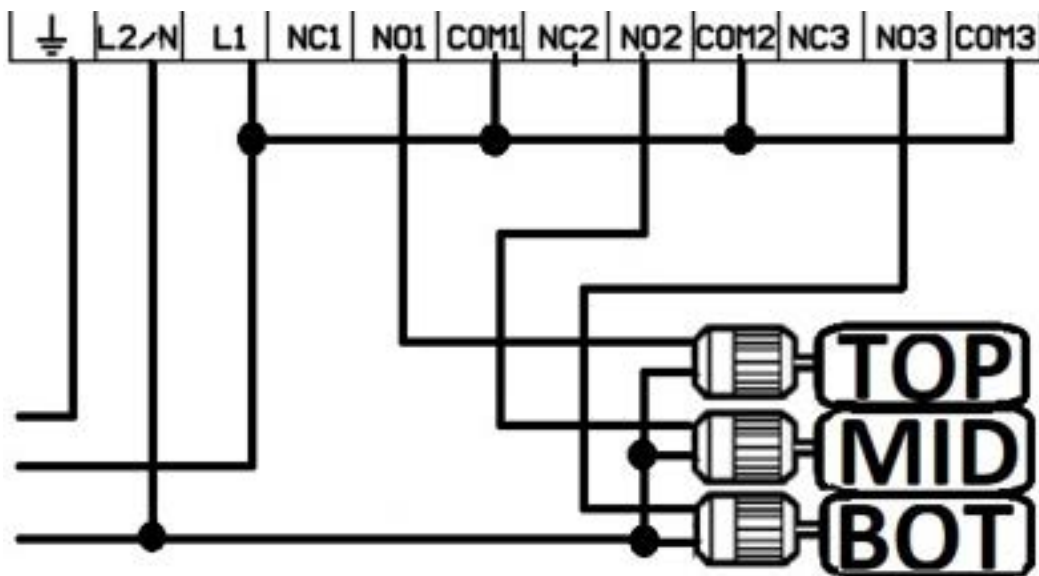

Specifications

Model	emPower R3 - V1 (e) options : emDoor, emWall ou emActuator
Voltage	100-240V AC
Consumption (Without connected devices)	10w
Maximal Current	15A par relay (Resistive) 0,5HP at 120v & 1HP at 240v.
Operation temperature	-40°C to 60°C -40°F to 140°F
Plastic	ABS V0 IP65
Frequencies	America: ISM 902 to 926 Mhz (emPower) Europe: 863 to 870 Mhz (emPower E)
Number of units	Up to 64006 on a same network
FHSS	15.6 ms, 50 channels
Internal memory	2 Mbits Flash
Antenna	Internal AWG24 85mm (3.0 dbi Gain)

Operation

The AgriMesh emPower R3 is a device that uses Penteract's WiseMesh technology. For information on WiseMesh technology and emMesh modules, visit the Penteract website at www.penteract.ca.

The AgriMesh emPower R3 device requires a wireless connection with an emHub device from AgriMesh.

For information on the emHub, consult the AgriMesh website at www.agrimesh.net

Energizing

Once power is restored to the AgriMesh emPower R3, make sure your emHub is powered on and connected to the Internet.

After about 5 minutes, using a computer, visit:

<http://www.agrimesh.net>

Follow the links to the AgriMesh console.

In the menu on the left, accessible via the web interface, go to the "All devices" page.

The list should contain the installed device. If after 5 minutes the unit is still not there, close the circuit breaker for at least 20 seconds and restart it. Allow another 5 minutes and resume the procedure.

If the device is still not visible, contact AgriMesh Technical Services.

Maintenance

Fuse change

Your emPower R3 is protected by three (3) fuses. It is possible in case of overvoltage that one or more of these fuses must be changed.

CAUTION :

Before opening the box and changing the fuses, make sure the circuit breakers are closed and there is no current on your wires. If in doubt, consult a certified electrician.

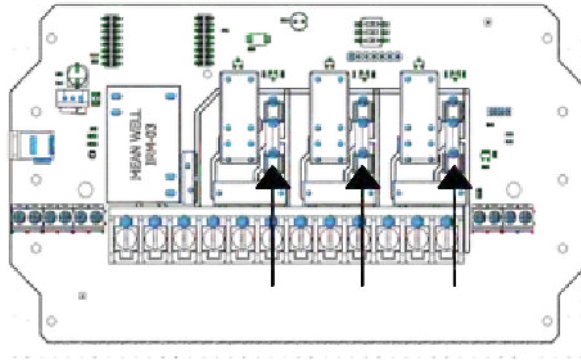

The three (3) fuses are shown here. For the changed, simply pulled gently on the fuse to release it from its support.

Replacement fuses must have the following specifications:

Format	Limit (Ampere)	Limit (Voltage)	Type
5mm x 20mm	15 A	250Vac	Slow Blow

CAUTION :

Replacing a fuse (s) with a fuse that does not meet the required specifications or anything else may result in equipment failure, personal injury, or even death. Consult an electrician if in doubt.

Warranty

ONE YEAR WARRANTY AgriMesh Technologies Inc. AgriMesh Technologies Inc. warrants to the consumer, the original purchaser of the emPower R3 product, that it is free from defects in material and workmanship for a period of one year from the date of purchase. original date of purchase. This warranty includes workshop service for the year. **THIS WARRANTY IS IN LIEU**



OF ALL OTHER WARRANTIES, EXPRESS OR IMPLIED, INCLUDING WARRANTIES OF MERCHANTABILITY AND FITNESS. AgriMesh Technologies Inc. **WILL NOT BE RESPONSIBLE IN ANY CASE FOR ANY CLAIMS FOR AN AMOUNT EXCEEDING THE ORIGINAL PURCHASE COST OF AN EMPOWER R3 MODULE HELD TO BE HELD LIABLE FOR ANY SUCH DAMAGE OR INCIDENT.** During the warranty periods noted above,

AgriMesh Technologies, at its option, will repair or replace, free of charge, any part or product deemed defective and that has been used and maintained in a normal manner. **THIS WARRANTY DOES NOT COVER FUSES.** In addition, this warranty does not cover (a) normal maintenance and service, (b) any part or product damaged as a result of misuse, neglect, accident, improper maintenance or repairs other than those performed under the supervision of AgriMesh Technologies Inc., or c) improper installation or installation not in accordance with the recommended installation method.

Warranty service must be performed by an authorized service center designated by AgriMesh Technologies Inc. The removal and reinstallation of the appliance is the responsibility of the consumer and can not be billed to AgriMesh Technologies inc. The duration of any implied warranty is limited to a period of one (1) year, as specified for the express warranty. Some provinces do not allow time limits on implied warranties. If this is the case, please disregard the last limit described above. **THE OBLIGATION THAT AGRIMESH TECHNOLOGIES INC INCORPORATES TO REPAIR OR REPLACE, TO ITS CHOICE, A PART OR PRODUCT, WILL BE THE SOLE AND EXCLUSIVE REMEDY OF THE PURCHASER. AGRIMESH TECHNOLOGIES INC. SHALL NOT BE LIABLE FOR ANY DIRECT, INDIRECT, SPECIAL DAMAGES CAUSED BY THE USE OR PERFORMANCE OF ITS PRODUCTS. SOME PROVINCES DO NOT ALLOW THE EXCLUSION OR LIMITATION OF DIRECT, INDIRECT OR SPECIAL DAMAGES. IF SO, PLEASE DO NOT TAKE INTO ACCOUNT THE EXCLUSION OR LIMITATION ABOVE.** This warranty gives you specific legal rights, and you may also have other rights which vary from state to state. This warranty voids all previous warranties. To contact the warranty service, contact **TECHNOLOGIES AGRIMESH**



INC at 1 (866) 781-9861. For a claim to be accepted, the owner of the emPower R3 must have the model and serial number of the device as well as proof of the date of purchase of the said product. Subsequently, the owner must describe the nature of the defect in the part or product.

Certifications



This equipment has been tested and found to comply with the limits for a Class B digital device, pursuant to Part 15 of the FCC Rules.

These limits are designed to provide reasonable protection. Regulatory information against harmful interference in a residential installation.

This equipment generates, uses and can radiate radio frequency energy. If it is not installed and used in accordance with the instructions, it may cause harmful interference to radio communications.

However, there is no guarantee that interference will not occur in a particular installation. If this equipment causes harmful interference to radio or television reception, which can be determined by turning the equipment off and on again, we encourage you to attempt to correct the interference by one or more of the following : receiving antenna, increase the distance between the equipment and the receiver, connect the equipment and receiver to the jacks of different circuits, or consult the dealer or an experienced radio / TV technician.

This equipment contains:

Radio emMesh 1.31 : FCC ID : 2ASI4EMMESH

Radio emMesh 1.31 : IC : 24776-EMMESH



This equipment, version E, complies with European wireless emission standards and may be used without risk of harmful interference. Make sure the device is type E designed for Europe.



This product is evaluated according to the model code SPE-1000. Such an assessment does not constitute certification, but is an accepted form of approval of electrical products by the competent authority. This approval is void if the product is changed.



Technologies AgriMesh Inc.

4000 Avenue Pinard, Saint-Hyacinthe
Québec, Canada
J2S 8K4

www.agrimesh.net